

FORNO SOLE MULTIFUNÇÃO DIGITAL 60 CM

FM-DG-60-SL-2TNB

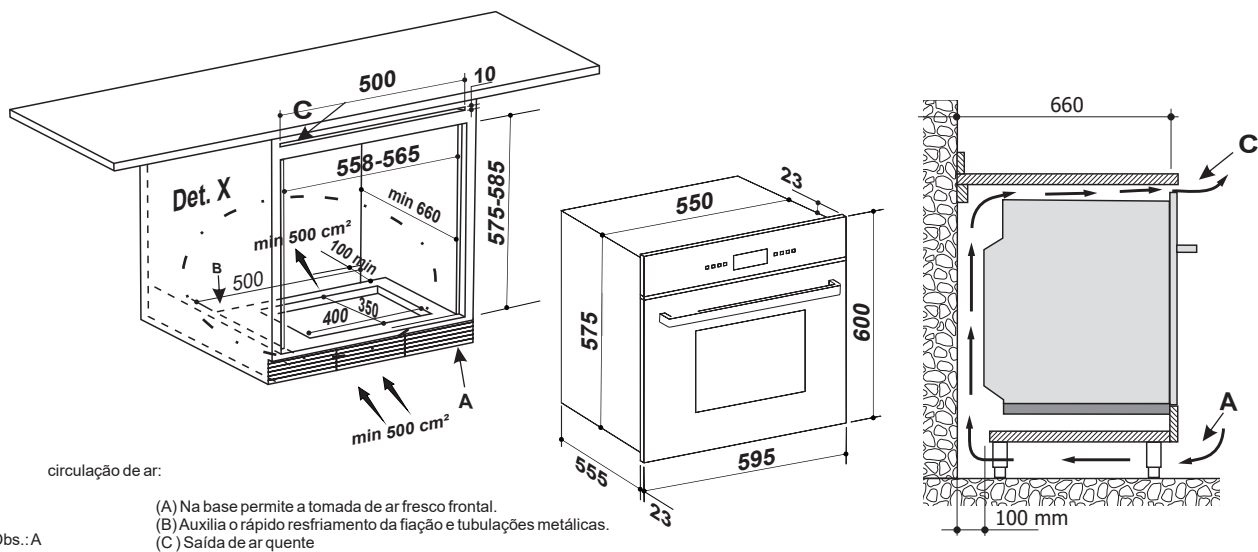
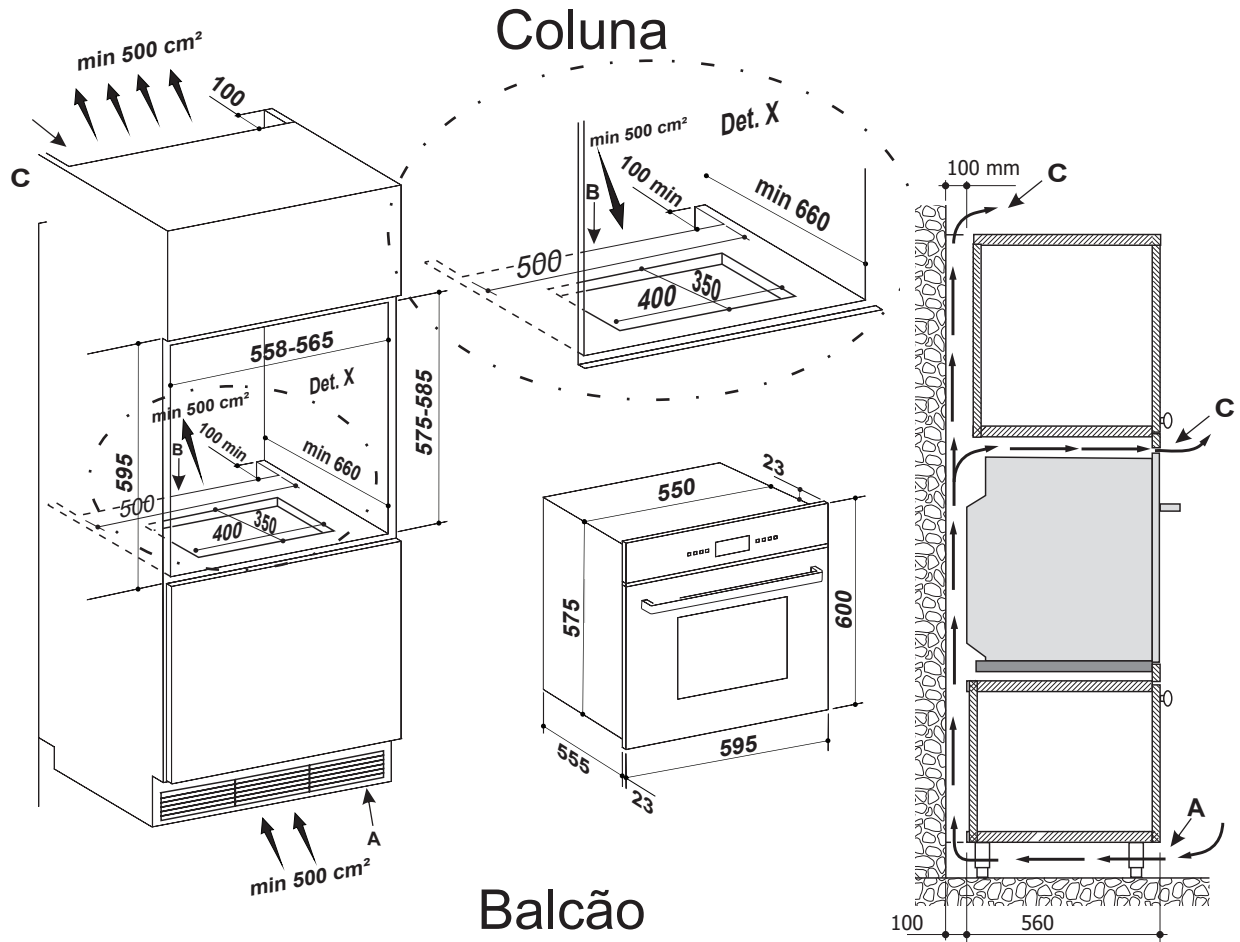

Medidas em milímetros
2018-01-10- V1-R0

Programa
de Relacionamento
inspire-se

ELETTROMECC
inspire-se

MICRO-ONDAS SOLE 40 LITROS BUILT-IN

FMC-FR-40-SL-2TNB

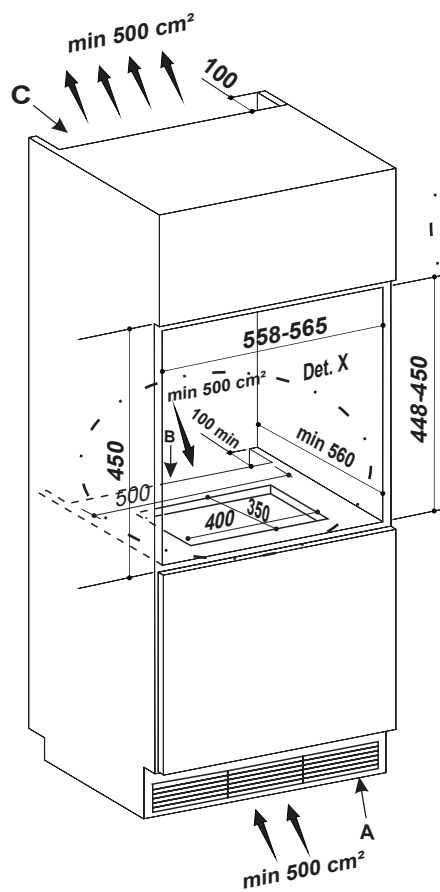

Coluna

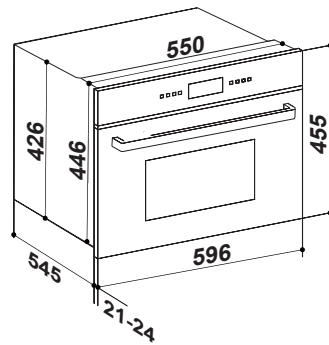
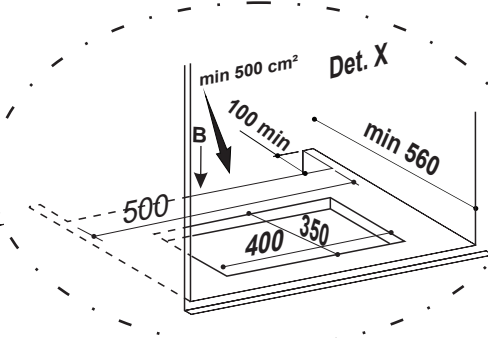

Balcão

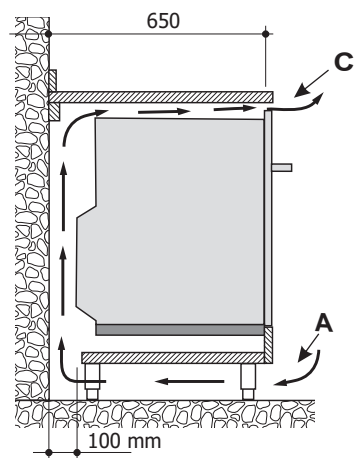
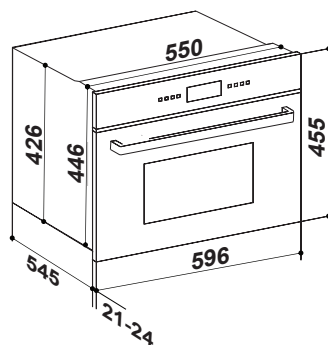
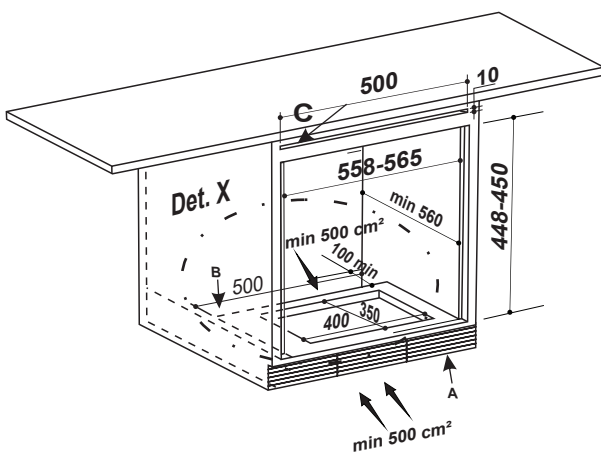
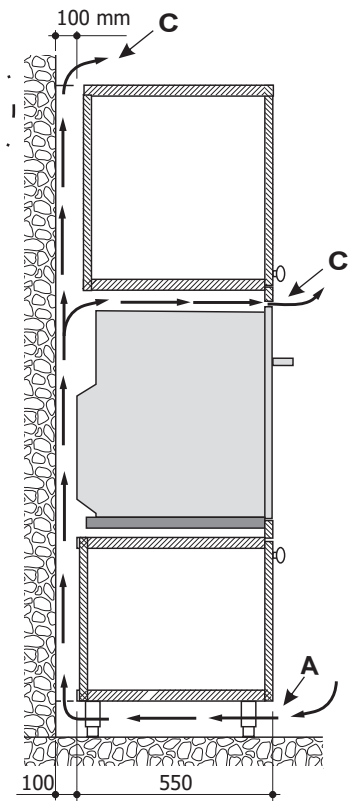

Obs.: A circulação de ar:

- (A) Na base permite a tomada de ar fresco frontal.
- (B) Auxilia o rápido resfriamento da fiação e tubulações metálicas.
- (C) Saída de ar quente

Medidas em milímetros
2018-01-10- V1-R0

Programa
de Relacionamento
inspire-se

ELETTROMECC
inspire-se

FORNO SOLE MULTIFUNÇÃO DIGITAL 60 CM E MICRO-ONDAS SOLE 40 LITROS BUILT-IN

FM-DG-60-SL-2TNB e FMC-FR-40-SL-2TNB

FMC-FR-34-SL-2TNB

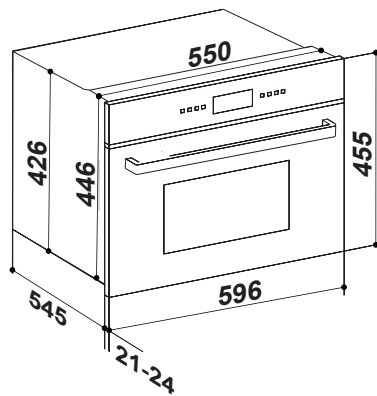

FM-DG-60-SL-2TNB

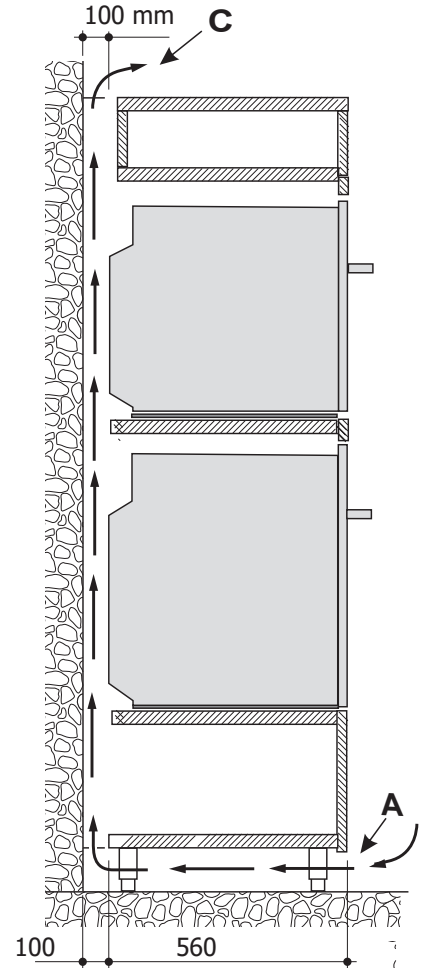
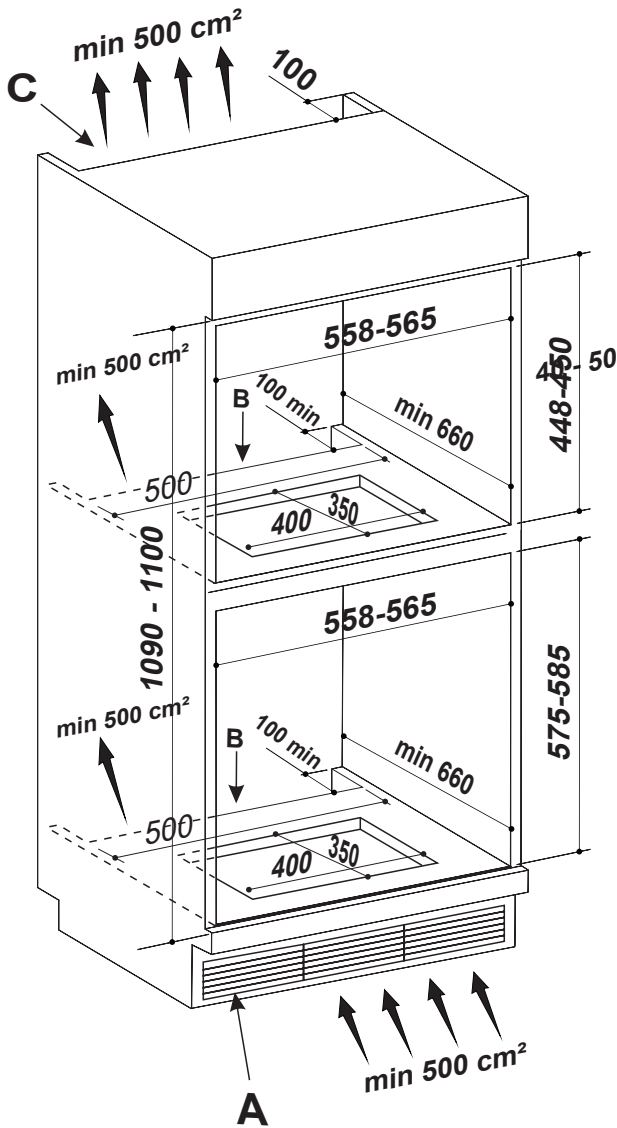
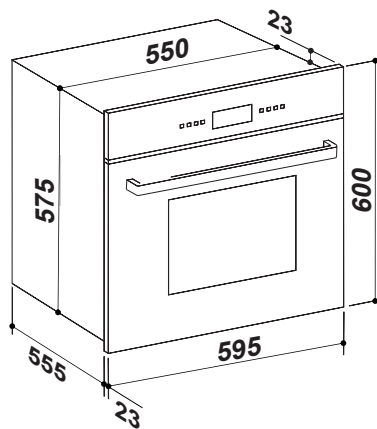

Obs.: A circulação de ar:

- (A) Na base permite a tomada de ar fresco frontal.
- (B) Auxilia o rápido resfriamento da fiação e tubulações metálicas.
- (C) Saída de ar quente

Medidas em milímetros
2018-01-10- V1-R0